

**INSTRUCTION MANUAL**  
*for*  
**APF-5060**  
**MAGNETIC FIELD  
GENERATOR**



## Table of Contents

<b>1.0</b>	<b>Introduction .....</b>	<b>5</b>
<b>2.0</b>	<b>Products Available from Com-Power .....</b>	<b>6</b>
<b>3.0</b>	<b>Product Information .....</b>	<b>7</b>
3.1	<i>Incoming Inspection.....</i>	7
3.2	<i>Package Inventory.....</i>	7
3.3	<i>Product Safety Information.....</i>	8
3.3.1	<i>Product Hazard Symbols Definitions.....</i>	8
3.3.2	<i>Product Warning/Caution Statements.....</i>	8
3.3.3	<i>General Safety Instructions.....</i>	9
3.4	<i>Product Features.....</i>	10
3.5	<i>Product Specifications.....</i>	13
<b>4.0</b>	<b>Assembly Instructions .....</b>	<b>15</b>
4.1	<i>Assembly Procedure for Antenna Mounting Structure.....</i>	15
<b>5.0</b>	<b>Input/Output Ports .....</b>	<b>18</b>
5.1	<i>System Input Power Port.....</i>	18
5.1.1	<i>Replacing the Power Input Fuse.....</i>	18
5.2	<i>Safety Interlock Port.....</i>	19
5.3	<i>Fiber Optic Port.....</i>	20
5.4	<i>Output Port.....</i>	20
<b>6.0</b>	<b>Front Panel Operation.....</b>	<b>21</b>
6.1	<i>Initial Startup.....</i>	21
6.2	<i>Quick Menu Access Screen.....</i>	22
6.3	<i>Operating Mode Selection Screen.....</i>	23
6.4	<i>STANDARD Test Setup Menu Screen.....</i>	24
6.5	<i>USER Test Setup Menu Screen.....</i>	25
6.6	<i>Test Setup Menus Navigation/Operation.....</i>	26
6.6.1	<i>Menu Navigation.....</i>	26
6.6.2	<i>Modifying Non-Numeric Surge Parameter Fields.....</i>	26
6.6.3	<i>Modifying Numeric Surge Parameter Fields.....</i>	27
6.7	<i>Run Test.....</i>	28
6.7.1	<i>Pausing the Test.....</i>	29
6.7.2	<i>Aborting the Test.....</i>	29
6.8	<i>Save Test.....</i>	30

---

<b>7.0</b>	<b>Performance of Tests.....</b>	<b>31</b>
7.1	<i>Performing Tests with Inductive Standard Coils .....</i>	<i>32</i>
7.2	<i>Preparation for Tests to be Performed with Inductive Non-Standard Coils.....</i>	<i>33</i>
7.2.1	<i>Determination of Coil Factor.....</i>	<i>33</i>
7.2.2	<i>Determination of Test Volume.....</i>	<i>36</i>
7.3	<i>Performing Tests with Inductive Non-Standard Coils.....</i>	<i>37</i>
<b>8.0</b>	<b>Troubleshooting.....</b>	<b>38</b>
8.1	<i>ERROR MESSAGE – Current Required to Set the Field Exceeds 120 Amps.....</i>	<i>38</i>
8.2	<i>ERROR MESSAGE – Unexpected Change in Output Current .....</i>	<i>38</i>
8.3	<i>ERROR MESSAGE – Unable to Set Level.....</i>	<i>38</i>
<b>9.0</b>	<b>Warranty.....</b>	<b>39</b>
<b>9.0</b>	<b>Maintenance.....</b>	<b>40</b>

## List of Figures

Figure 1 - Product Features – APF-5060 (Front).....	10
Figure 2 - Product Features – APF-5060 (Rear).....	11
Figure 3 - APF-5060 Accessories.....	12
Figure 4 - Product Dimensions.....	14
Figure 5 - Assembly Instructions - Coil Mounting Structure – Step #1.....	15
Figure 6 - Assembly Instructions - Coil Mounting Structure – Step #2.....	15
Figure 7 - Assembly Instructions - Coil Mounting Structure – Step #3.....	16
Figure 8 - Assembly Instructions – Coil Mounting Structure – Step #4.....	16
Figure 9 - Assembly Instructions - Coil Mounting Structure – Step #5.....	17
Figure 10 - Assembly Instructions - Coil Mounting Structure – Step #6.....	17
Figure 11 - Accessing the Power Input Fuse.....	18
Figure 12 - Safety Interlock Connector Pin-Out & Ext. Switch Connection.....	19
Figure 13 - STANDARD Test Setup Menu Options.....	24
Figure 14 - USER Test Setup Menu Options.....	25
Figure 15 - User-Changeable Test Parameters.....	26
Figure 16 - Test Setup Menu Options with Allowed Digit Ranges.....	27
Figure 17 - Basic Test Setup for Table Top EUT (3-axis).....	31
Figure 18 - STANDARD Test Setup Menu Options.....	32
Figure 19 - Setup for Magnetic Field Measurement for Coil Factor Determination.....	33
Figure 20 - Test Volume for a 1m x 1m Inductive Standard Coil.....	36
Figure 21 - USER Test Setup Menu Options.....	37

## List of Tables

Table 1 - Product Specifications.....	13
---------------------------------------	----

## List of Equations

Equation 1 - Conversion from Gauss & Tesla to A/m.....	34
Equation 2 - Calculation of Coil Factor (C.F.).....	35
Equation 3 - Calculation of Generator Output/Coil Current.....	35

## **1.0 Introduction**

This manual includes description of product features, product specifications, instructions for use, important safety precautions, warranty and maintenance information.

The test procedures and guidance provided herein is for general guidance and is correct to the extend of our knowledge and understanding of the current, relevant IEC/EN standards at the time that this manual was written. However, the information may become dated or may be inappropriate for some applications.

The user is cautioned to always refer to the appropriate editions of the relevant standards to ensure proper application of the test and adherence to the most appropriate rules, procedures, practices, and/or interpretations thereof for your particular application.

Information contained in this manual is the property of Com-Power Corporation. It is issued with the understanding that the material may not be reproduced or copied without the express written permission of Com-Power.

## 2.0 Products Available from Com-Power



Antennas



Antenna  
Kits



Absorbing  
Clamps



Coupling/Decoupling  
Networks (CDNs)



Comb  
Generators



Current Probes  
& Injection Probes



Emissions  
Test Systems



Conducted Immunity  
Test Systems



Impedance Stabilization  
Networks (ISNs)



Line Impedance  
Stabilization Networks (LISNs)



Antenna  
Masts



Near-Field  
Probe Sets



Preamplifiers



Power  
Amplifiers



Spectrum  
Analyzers



Surge  
Generators



Transient  
Limiters



Turntables



Antenna  
Tripods



Telecom  
Test Systems

[www.com-power.com](http://www.com-power.com)

SECTION 2 - PRODUCTS AVAILABLE FROM COM-POWER

19121 EL TORO ROAD • SILVERADO, CALIFORNIA 92676 • (949) 459-9600 • [com-power.com](http://com-power.com)

Rev091918

## 3.0 Product Information

### 3.1 Incoming Inspection



**WARNING** – To avoid possibility of electrical shock, do not apply power to the product or any of its accessories if there is any evidence of shipping damage. If shipping damage to the product or any of the accessories is suspected, or if the package contents are not complete, contact Com-Power or your Com-Power distributor.

Please check the contents of the shipment against the package inventory in section 3.2 to ensure that you have received all applicable items.

### 3.2 Package Inventory

#### STANDARD ITEMS:

- ✓ APF-5060 Magnetic Field Generator
- ✓ APF-5060-11 1m x 1m Inductive Standard Coil
- ✓ APF-5060-ANTPOS Antenna Positioner
- ✓ APF-5060-COILSTND Antenna Stand Base with 1.5m Boom
- ✓ (2) 1.2-meter Output Cables
- ✓ (2) Boom clamps
- ✓ Safety Interlock Port Key
- ✓ 4-pin, 7mm, Push-Pull Connector
- ✓ IEC Power Cord

#### OPTIONAL ITEM:

- ✓ APF-5060-EUTSTND EUT Stand

### 3.3 Product Safety Information

#### 3.3.1 Product Hazard Symbols Definitions

The hazard symbols appearing on the product exterior are defined below.



The yellow triangle with an exclamation mark indicates the presence of important operating and/or maintenance (servicing) instructions in the literature accompanying the product.



The yellow triangle with a magnet indicates the presence of high magnetic fields, which can cause implanted heart pacemakers and cardioverter defibrillators to cease operation. Maintain a safe distance of at least 12 inches (30 cm) from this equipment and its inductive coil antenna.



The Ground symbol inside a circle indicates the presence of a terminal which is intended for connection to an external ground conductor for protection against electric shock in case of a fault, or the terminal of a protective earth (ground) electrode.



indicator on the rating plate that the equipment is suitable for AC current.

#### 3.3.2 Product Warning/Caution Statements

The following warnings/caution statements must be adhered to in order to ensure safe operation of the product.



**CAUTION:**

FOR CONTINUED PROTECTION AGAINST RISK OF FIRE,  
REPLACE ONLY WITH SAME TYPE AND RATING OF FUSE.

**WARNING:**

TO PREVENT ELECTRIC SHOCK, DO NOT OPEN COVER  
SERVICING ONLY BY QUALIFIED PERSONNEL  
NO USER SERVICEABLE PARTS INSIDE.



### 3.3.3 General Safety Instructions

The following safety instructions have been included in compliance with safety standard regulations. Please read them carefully.

- **READ AND RETAIN INSTRUCTIONS** - Read all safety and operating instructions before operating the instrument. Retain all instructions for future reference.
- **HEED WARNINGS** - Adhere to all warnings on the instrument and operating instructions.
- **FOLLOW INSTRUCTIONS** - Follow all operating and use instructions.
- **WATER AND MOISTURE** - Do not use the instrument near water.
- **VENTILATION** - The instrument should be used/installed only in locations where the flow of air through the ventilation openings is not impeded.
- **MOUNTING** – The instrument can be used in Horizontal or vertical orientation as long as the ventilation holes are not obstructed and the protective grounding is not defeated.
- **HEAT** - The instrument should be situated away from heat sources such as heat registers or other instruments which produce heat.
- **POWER SOURCES** - Connect the instrument only to the type of power source described in the operating instructions or as marked on the instrument.
- **GROUNDING** - Take precautions to insure that the grounding of the instrument is not defeated. Grounding conductor with adequate cross-section must be connected to earth ground.
- **POWER CORD PROTECTION** - Place power supply cord so that it is not likely to be walked on or pinched by items placed on them or against them.
- **CLEANING** – Clean the instrument outside surfaces of the device with a soft, lint-free cloth. If necessary, a mild detergent may be used.
- **NON-USE PERIODS** - Unplug the power cord of the instrument when it will be left unused for a long period of time.
- **OBJECT AND LIQUID ENTRY** - Take care that objects do not fall into the instruments and that liquids are not spilled into the enclosure through openings.
- **DEFECTS AND ABNORMAL STRESS** - Whenever it is likely that the normal operation has been impaired, make the equipment inoperable and secure it against further operation.
- **SITTING OR CLIMBING** - Do not sit or climb upon the instrument or use it as a step or ladder.
- **ENVIRONMENTAL CONDITIONS** - This equipment is designed for indoor use. Ambient temperature range during operation should be between 5° C to 40° C.
- **STORAGE AND PACKAGING** - The device should only be stored at a temperature between –25 and +70 °C. During extended periods of storage, protect the device from dust accumulation. The original packaging should be used if the device is transported or shipped again. If the original packaging is no longer available, the device should be packed carefully to prevent mechanical damage.



### 3.4 Product Features

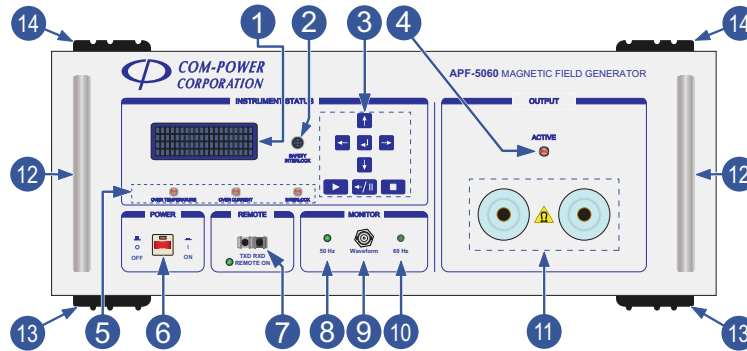

**Figure 1 – Product Features – APF-5060 (Front)**

- 1 LCD Display**  
Used in conjunction with control keypad to operate generator from the front panel.
- 2 Safety Interlock Port**  
This is a safety interlock port. Refer to section 5.2 for details.
- 3 Control Keypad**  
For locally controlling the generator. Refer to section 6.6.1 for details.
- 4 OUTPUT ACTIVE LED Indicator**  
When illuminated, indicates that the output of the generator is active.
- 5 Instrument Status LED Indicators**  
These three LED indicators, when illuminated, provide indications in case of over-temperature, over-current and/or the safety interlock circuit is open.
- 6 Front Panel Power Switch**  
Used to turn on/off system power when the rear panel power switch is in the 'ON' position.
- 7 REMOTE Fiber Optic Port and LED Indicator**  
CURRENTLY NOT SUPPORTED.
- 8 50 Hz LED Indicator**  
When illuminated, indicates that the output frequency of the generator is set to 50 Hz.
- 9 WAVEFORM Port**  
This port may be connected to an oscilloscope to verify the output frequency of the generator. The waveform present at this output port is a 2.7Vrms square wave. This port is equipped with a female BNC-type connector.
- 10 60 Hz LED Indicator**  
When illuminated, indicates that the output frequency of the generator is set to 60 Hz.
- 11 Generator Output Terminals**  
The Generator Output Terminals are equipped with Superior Electric Sockets for connection to the inductive loop coil.
- 12 Front Panel Handles**  
These handles are typically used for rack-mount installation; for sliding the generator in and out of the rack.
- 13 Bottom-side Rubber Feet (front)**  
For rack-mount installation, these feet may be removed by removing the two screws (per foot) which attach the feet to the chassis. The screws can then be removed from each foot and screwed back into their respective holes to re-secure the bottom cover.
- 14 Top-side Rubber Feet (front)**  
For rack-mount installation, these feet may be removed by removing the two screws (per foot) which attach the feet to the chassis. The screws can then be removed from each foot and screwed back into their respective holes to re-secure the top cover.

#### SECTION 3 - PRODUCT INFORMATION

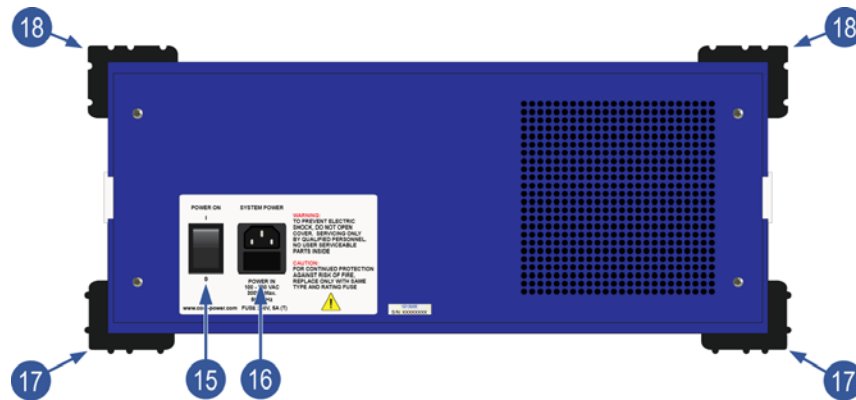

**Figure 2 - Product Features – APF-5060 (Rear)**

- 15 Rear Panel Power Switch**  
Used to turn on/off power supplied to the front panel power switch.
- 16 System Power Input Port and Fuse Compartment**  
Power input module with IEC C13 inlet and fuse compartment.
- 17 Bottom-side Rubber Feet (rear)**  
For rack-mount installation, these feet may be removed by removing the two screws (per foot) which attach the feet to the chassis. The screws can then be removed from each foot and screwed back into their respective holes to re-secure the bottom cover.
- 18 Top-side Rubber Feet (rear)**  
For rack-mount installation, these feet may be removed by removing the two screws (per foot) which attach the feet to the chassis. The screws can then be removed from each foot and screwed back into their respective holes to re-secure the top cover.

SECTION 3 - *PRODUCT INFORMATION*

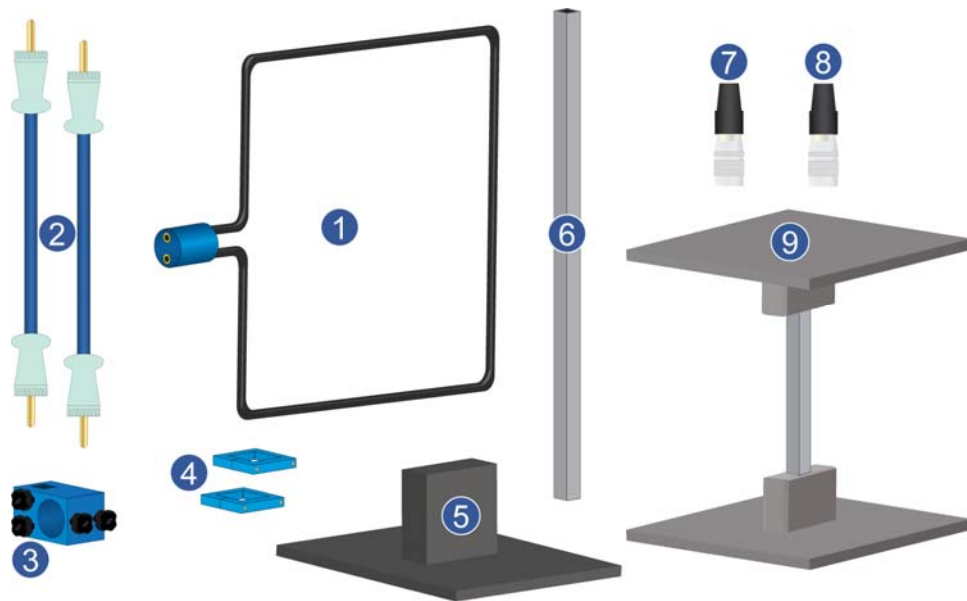

**Figure 3 - APF-5060 Accessories**

- 1 APF-5060-11 Coil**  
1m x 1m Inductive Standard Coil.
- 2 Generator Output Cables**  
(2) #2 AWG cables used to connect the output of the generator to the input of the antenna coil.
- 3 APF-5060-ANTPOS Antenna Positioner**  
Provides mounting mechanism for inductive coil. Installs onto 1.5 meter coil stand boom and allows height adjustment of antenna.
- 4 Boom clamps**  
Can be mounted in fixed positions on boom as stoppers for the antenna positioner.
- 5 APF-5060-COILSTND Coil Stand**  
Provides mounting provisions for 1.5 meter boom.
- 6 1.5 meter Boom**  
1.5 meter vertically mounted beam on which antenna positioner is mounted.
- 7 Safety Interlock Port Key**  
Connect this key to the safety interlock port to enable operation when no external switch is utilized. Refer to section 5.2.
- 8 4-pin, 7 mm, Push-Pull Connector**  
Used to connect external switch to safety interlock port. Refer to section 5.2.
- 9 APF-5060-EUTSTND EUT Stand (optional)**  
To be used as support for table-top Equipment Under Test (EUT).

SECTION 3 - *PRODUCT INFORMATION*

### 3.5 Product Specifications

**Table 1 – Product Specifications**

GENERAL	
<i>Application</i>	<b>Power Frequency Magnetic Field Tests</b>
<i>Standard(s)</i>	<b>IEC 61000-4-8</b>
<i>Output Frequencies</i>	<b>50/60 Hz</b>
<i>Magnetic Field</i>	<b>1 A/m to 100A/m*</b> (adjustable in 1 A/m increments) <i>*with APF-5060-11 Inductive Coil</i>
<i>Maximum Output Current</i>	<b>120 Amperes</b>
<i>Total Harmonic Distortion</i>	<b>≤8%</b>
<i>Coil Factor</i>	<b>0.01 to 99.99</b> (adjustable in increments of 0.01)
<i>Test Duration (hrs/min/sec)</i>	<b>00:00:01 to 10:59:59</b> (adjustable in 1 second increments)
ELECTRICAL	
<i>AC Input Power</i>	<b>100-250 Volts AC, 50/60 Hz</b> <b>300 Volt-Amp (VA)</b> (maximum)
INPUT/OUTPUT CONNECTORS	
<i>Waveform Output Connector</i>	<b>BNC</b> (female)
<i>Test Output Connectors</i>	<b>(2) x Superior Electric RS100GBL SUPERCON Socket Receptacles</b>
<i>AC Input Connector</i>	<b>IEC C13 Inlet Plug</b>
ENVIRONMENTAL	
<i>Operating Temperature</i>	<b>40° F to 104° F</b> (5° C to 40° C)
<i>Cooling</i>	<b>Forced Air</b>
MECHANICAL	
<i>Dimensions (H) x (W) x (D)</i>	<b>7.75" x 19" x 19.3"</b> (19.7 cm x 48.3 cm x 49 cm)
<i>Rack Mount Dimensions</i> (top/bottom feet removed, not including front handles)	<b>(4U) 7" x 19" x 18.3"</b> (17.8 cm x 48.3 cm x 46.5 cm)

*All values are typical, unless specified.  
All specifications are subject to change without notice.*

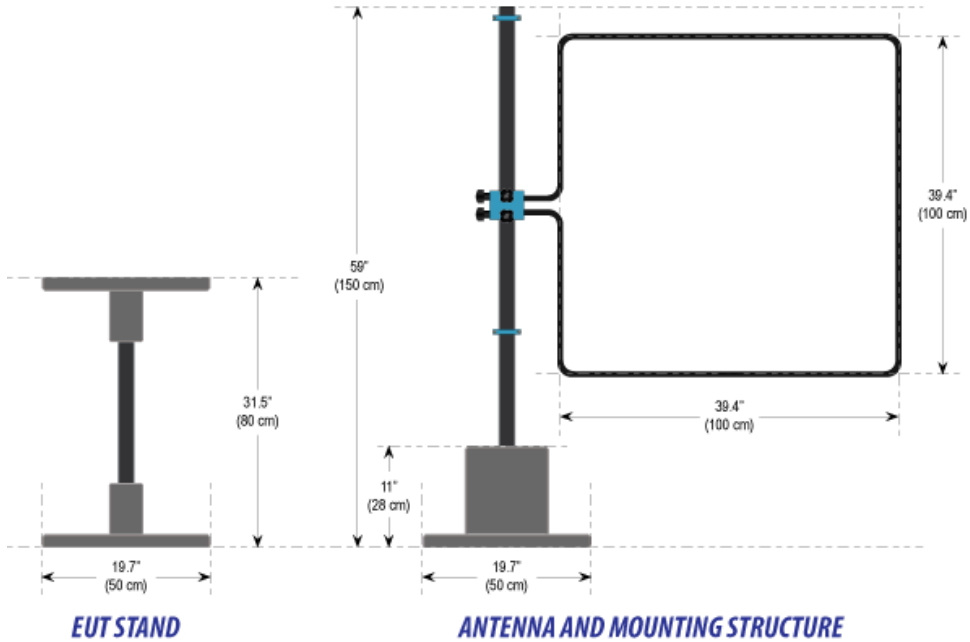
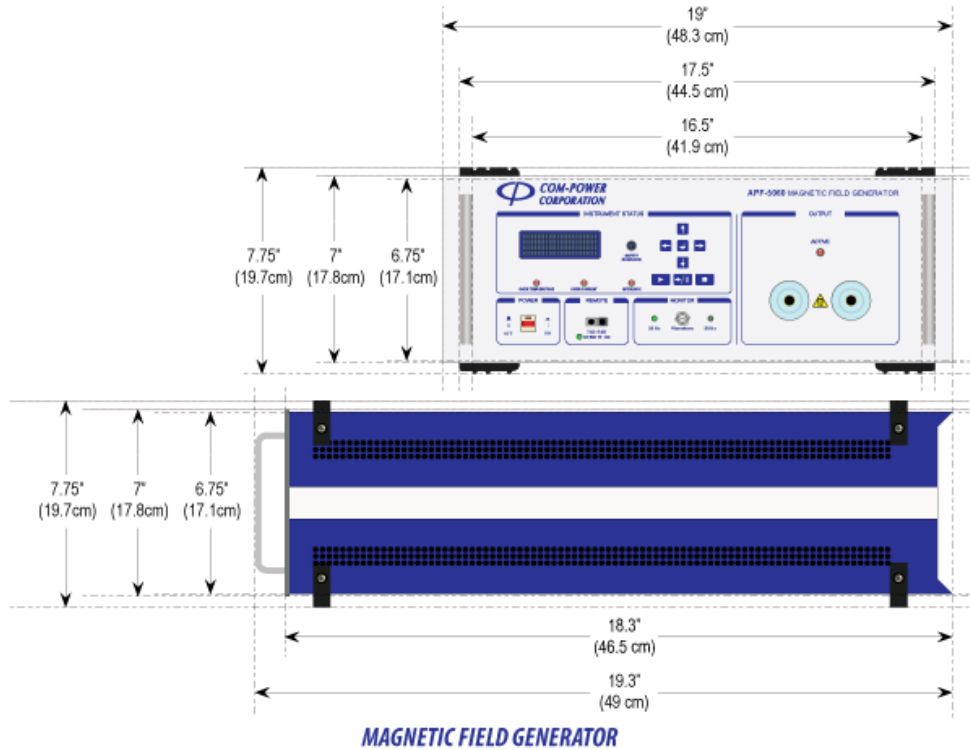

**Figure 4 - Product Dimensions**

SECTION 3 - *PRODUCT INFORMATION*

## 4.0 Assembly Instructions

### 4.1 Assembly Procedure for Antenna Mounting Structure

Step #1 Slide the 1.5-meter boom<sup>6</sup> into the coil stand<sup>5</sup> as shown in Figure 5.

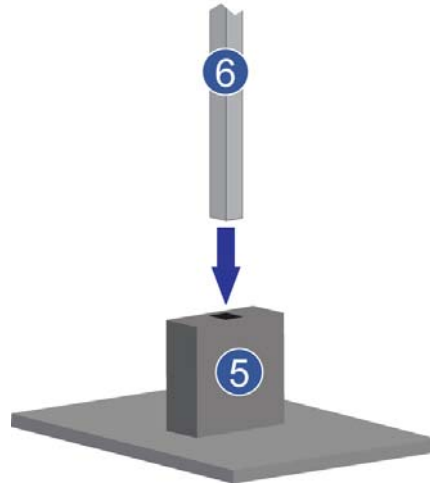

**Figure 5 - Assembly Instructions - Coil Mounting Structure - Step #1**

Step #2 Slide one of the boom clamps<sup>4</sup> onto the boom and into the desired position as shown in Figure 6. Tighten into position using a 5 mm Allen wrench.

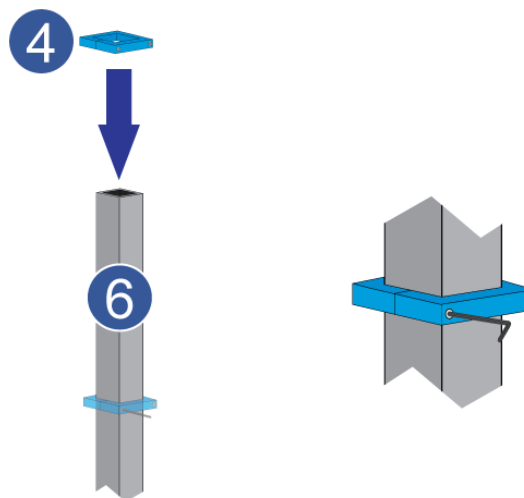

**Figure 6 - Assembly Instructions - Coil Mounting Structure - Step #2**

**Step #3** Slide the antenna positioner<sup>3</sup> onto the boom<sup>6</sup> as shown in Figure 7. Tighten the finger-knob bolts (clockwise) to lock the positioner into the desired position.

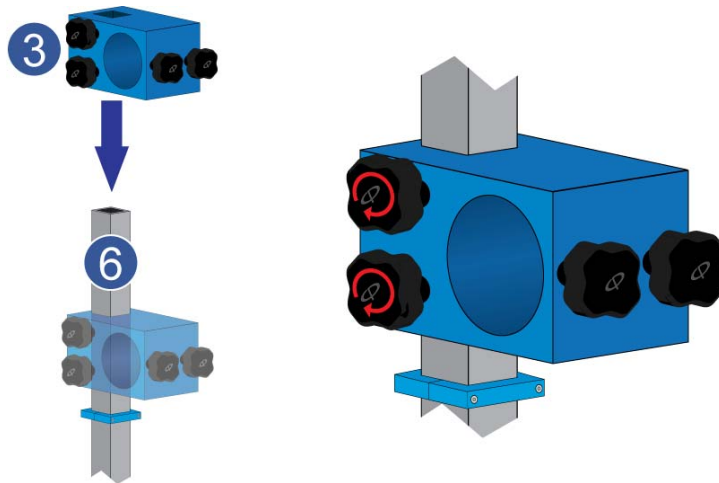

**Figure 7 - Assembly Instructions - Coil Mounting Structure – Step #3**

**Step #4** Slide the second boom clamp<sup>4</sup> onto the boom and into the desired position as shown in Figure 8. Tighten into position using a 5 mm Allen wrench.

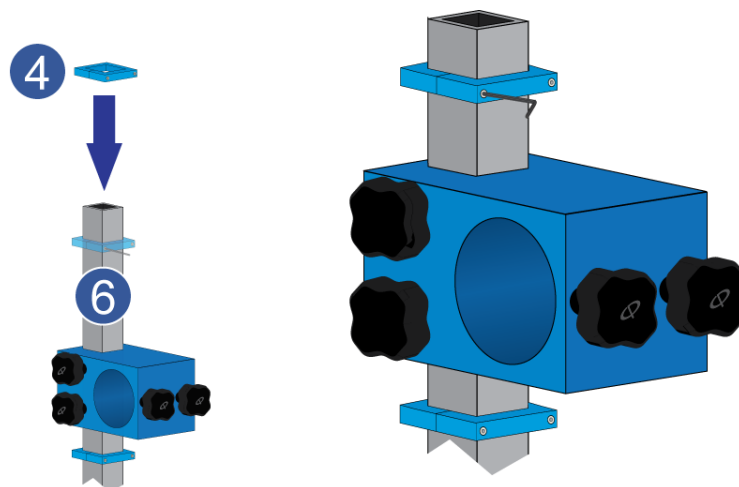
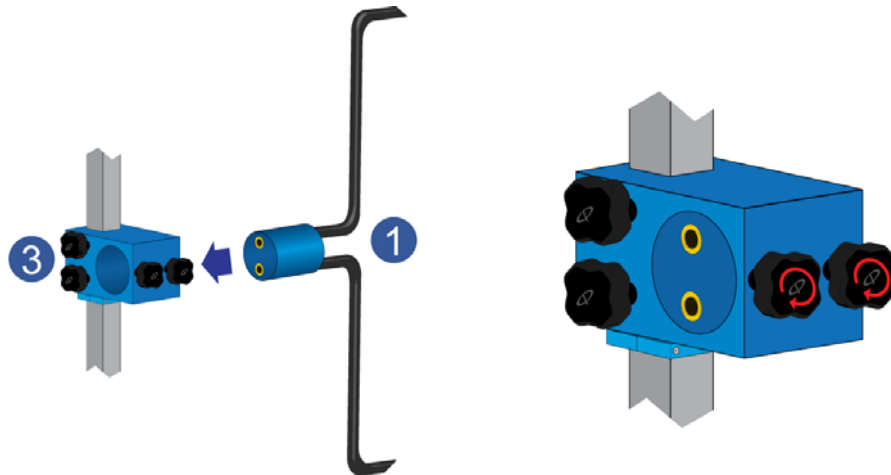

**Figure 8 – Assembly Instructions – Coil Mounting Structure – Step #4**

SECTION 4 - ASSEMBLY INSTRUCTIONS



**Step #5** Insert the blue cylinder attached to the rear of the APF-5060-11 coil<sup>1</sup> into the cylindrical hole in the antenna positioner<sup>3</sup> as shown in Figure 9. Place the coil in the desired orientation and tighten the finger-knob bolts (clockwise) to secure.



**Figure 9 - Assembly Instructions - Coil Mounting Structure – Step #5**

**Step #6** Using the (2) generator output cables<sup>2</sup>, connect the generator output to the loop coil input as shown in Figure 10.

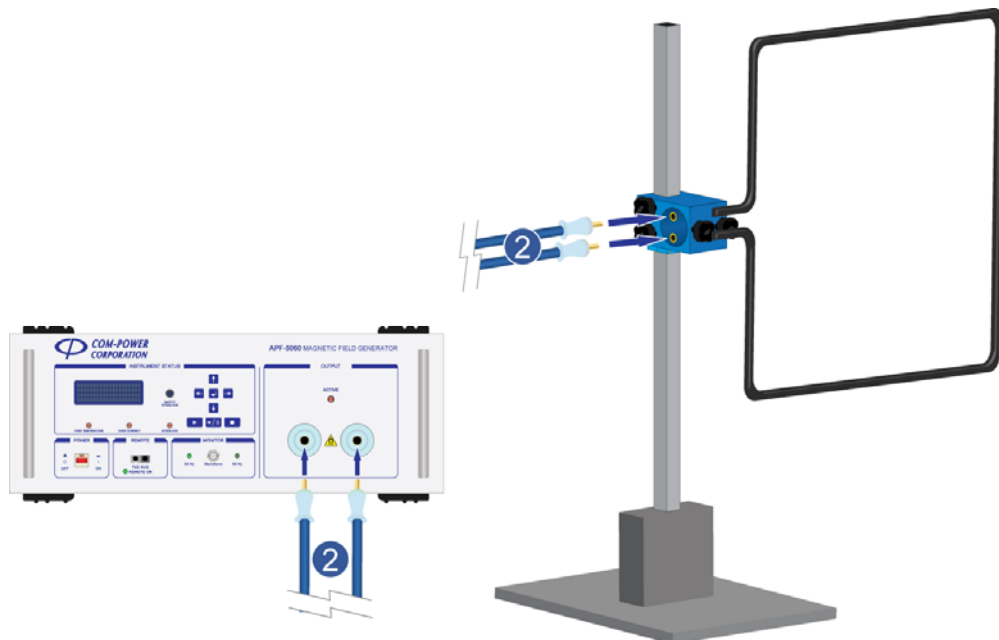

**Figure 10 - Assembly Instructions - Coil Mounting Structure – Step #6**

SECTION 4 - ASSEMBLY INSTRUCTIONS

## 5.0 Input/Output Ports

In the following sections, guidance is provided pertaining to the external electrical connections/interconnections of the APF-5060 System and accessories. The guidance is given on a port-by-port basis.

### 5.1 System Input Power Port

**WARNING - DO NOT EXCEED THE RELEVANT INPUT POWER SPECIFICATIONS DETAILED IN SECTION 3.5 AND ON THE REAR PANEL OF THE GENERATOR.**

The APF-5060 requires the following power source:

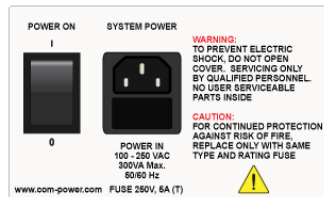

Voltage:	100-250 V <sub>AC</sub>
Frequency:	50/60 Hz
Power:	300VA Maximum

In accordance with international safety standards, this instrument is equipped with a three-wire power cable. When connected to an appropriate AC power outlet, this cable grounds the instrument frame.

**WARNING:** TO PREVENT ELECTRIC SHOCK, DO NOT OPEN COVER. SERVICING ONLY BY QUALIFIED PERSONNEL. NO USER SERVICEABLE PARTS INSIDE.

**CAUTION:** FOR CONTINUED PROTECTION AGAINST RISK OF FIRE, REPLACE ONLY WITH SAME TYPE AND RATING OF FUSE.



The power plug must be plugged into an outlet that provides a protective earth ground connection.

#### 5.1.1 Replacing the Power Input Fuse

To access fuse, insert the end of a small flat-blade screwdriver into the slot on the top side of the fuse compartment as shown in Figure 11.

Replace fuse only with fuse of the same type, voltage rating and current rating [**250V, 5A (T)**]. After replacing fuse, slide fuse holder firmly back into position within its cavity.

One replacement fuse is located in the front slot of the fuse compartment. The active fuse is located at the rear of the compartment.



**Figure 11 - Accessing the Power Input Fuse**

## 5.2 Safety Interlock Port



### SAFETY INTERLOCK

The safety interlock port (left) can [optionally] be wired to an external SPST switch that will disable the generator output upon the opening of the switch contacts. This mechanism can be used to set up a safety perimeter around the testing area. **In cases where no external switch is used, simply connect the safety interlock key (right) to this port to enable the generator.**



For those cases where an external switch is to be used, wire your switch contacts to pins 2 and 3 of the supplied, spare 7mm push-pull connector as shown in Figure 12.

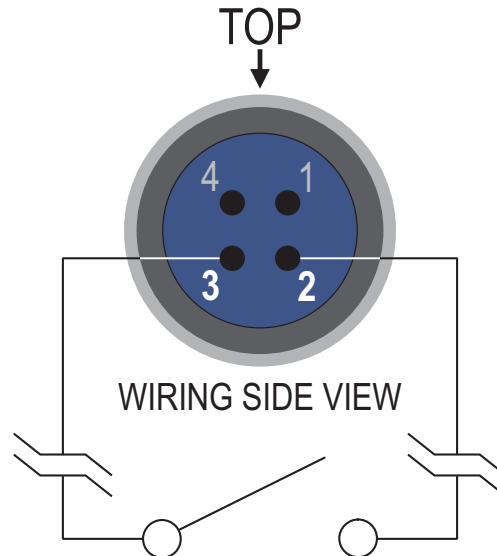

**Figure 12 - Safety Interlock Connector Pin-Out & Ext. Switch Connection**

Remove the interlock key from the interlock port, and plug in the wired switch assembly. The generator will now be enabled/disabled with the closing/opening of the switch contacts.

#### **WARNINGS:**

- DO NOT** connect the safety interlock port to a power source.
- Route the interlock cable AWAY from the EUT output.
- DO NOT** connect the safety interlock port to the EUT.
- DO NOT** use a momentary switch to control the interlock.
- Use a cable having twice the voltage rating of the EUT.

### 5.3 Fiber Optic Port

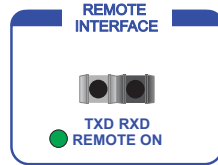

The remote interface port is currently not supported.

### 5.4 Output Port

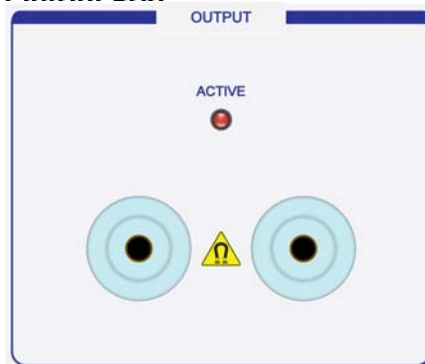

The output ports of the APF-5060 Magnetic Field Generator are intended ONLY for connection to inductive coils for the purpose of generating magnetic fields for immunity testing.

The port is fitted with two (2) Superior Electric RS100GBL SUPERCON Socket Receptacles.

**WARNING:**



**HIGH MAGNETIC FIELD.** Can cause implanted heart pacemakers and cardioverter defibrillators to cease operation. Maintain a safe distance of at least 12 inches (30 cm) from this equipment and its inductive coil antenna.

## 6.0 Front Panel Operation

The APF-5060 Magnetic Field Generator is able to perform all of its individual functions from the front panel interface, as described in the following sections.

### 6.1 Initial Startup

To turn on the generator, locate the **NEMA 5-15R-male to IEC C13-female** power cord supplied with the generator. Plug the IEC C13 plug end of the cord into the system power input port on the rear panel of the generator. Plug the other end of the power cord into an appropriate power outlet.

Turn on the power switch located on the rear panel. Then, press the SYSTEM POWER button on the lower left corner of the front panel; the system will power up.

After power-up, the following splash screens will appear successively.

```
COM - POWER  CORP .  
APF - 5060  
MAGNETIC FIELD  
GENERATOR
```

```
APF - 5060  
S / N :  x x x x x x x x  
F I R M W A R E  V E R . :  3 . 0
```

No user action is required at this point.



## 6.2 Quick Menu Access Screen



After the flash screens, the following screen will appear on the display:

```

DO YOU WANT TO
ACCESS THE QUICK
MENU?
YES                               NO
```

The default selection for this screen is NO. Pressing  without changing the selected option will take you to the OPERATING MODE selection screen.



To access this menu, from the above screen, press the  button to change the selection from NO to YES, and press . The QUICK MENU will be displayed.

To access the QUICK MENU from any other screen, press the  button until you reach the QUICK MENU ACCESS OPTION screen (shown above), press the  button to change the selection from NO to YES, and press the  button.

The QUICK MENU contains any previously saved test setups. The quick menu is shown to the right. Up to ten (10) test setups can be stored at any one time, and may be accessed from this menu.

```

1 ) 0 0 3 A / m   5 0 H z   1 x 1
2 ) 0 0 1 A / m   5 0 H z   0 8 . 5 0
3 ) 0 1 0 A / m   5 0 H z   0 1 . 0 0
↓ - DOWN   ← - OK   ↑ - UP
```

Use the  and  buttons on the control pad to scroll through the items saved in the QUICK MENU. Press the  button to select any saved test setup, which will

```

LEVEL : 0 0 1 A / m   F : 5 0 H z
COIL  : 1 m   x   1 m
TIME  : 0 0 : 1 0 : 0 0
▶ - RUN   ← - OK   ■ - SAVE
```



take you to the test setup screen for the operating mode (USER or STANDARD) which was used to create the selected test setup.

To DELETE ALL saved test setups from the QUICK MENU, hold down the  button for three seconds; the screen to the right will appear.

The default selection for this screen is 'NO'. Pressing  with 'NO' selected will return you to the QUICK MENU.

```

DO YOU WANT TO
DELETE ALL SAVED
TASKS?
YES                               NO
```

If you are sure that you want to delete all stored tasks (test setups), change the selection from NO to YES by pressing the  button. Then, press the  button to complete the action. DELETING ALL

```

1 ) E M P T Y
2 ) E M P T Y
3 ) E M P T Y
↓ - DOWN   ← - OK   ↑ - UP
```

TASKS CANNOT BE UNDONE. When the process is completed, you will be returned to the QUICK MENU. All memory slots will be empty.

### SECTION 6 - FRONT PANEL OPERATION

### 6.3 Operating Mode Selection Screen



Selecting 'NO' on the Quick Menu Access Screen, or pressing  from the test setup screen in either operating mode will bring you to the operating mode selection screen.



As shown, the two operating mode options are **USER** and **STANDARD**. The differences between these modes is defined below.

In the **STANDARD** operating mode, only the inductive standard coils defined in the IEC 61000-4-8 standard can be used; the 1m x 1m coil provided with your generator, and also the optional 1m x 2.6m coil(s). The coil factors for each are pre-programmed into the generator and cannot be changed.

In the **USER** operating mode, the option for selecting the coil to be used is replaced by an entry field for a numeric **COIL FACTOR**. This allows the user to perform tests with non-standard inductive coil antennas.

The default selection for this screen is the **STANDARD** operating mode. Pressing  without changing the selected option will take you to the **STANDARD Test Setup Menu** screen. To select the **USER** operating mode, press the  button to change the selection from **STANDARD** to **USER**, and press  to be taken to the **USER Test Setup Menu** screen.

### 6.4 STANDARD Test Setup Menu Screen

From this menu, the user is able to:

- select the desired **TEST LEVEL**;
- select the desired **TEST FREQUENCY**;
- select the **COIL** to be used;
- enter the **TIME**, or duration of the test;
- RUN** the test using the defined test parameters; and,
- SAVE** the test setup, so that it can be accessed later from the Quick Access Menu (see section 6.3).

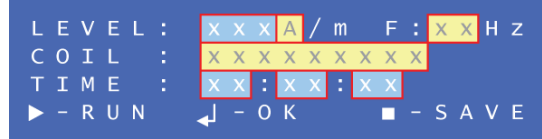

Shown in Figure 13 are the available menu options and/or allowed numeric ranges for the test parameters on the STANDARD Test Setup Menu screen.

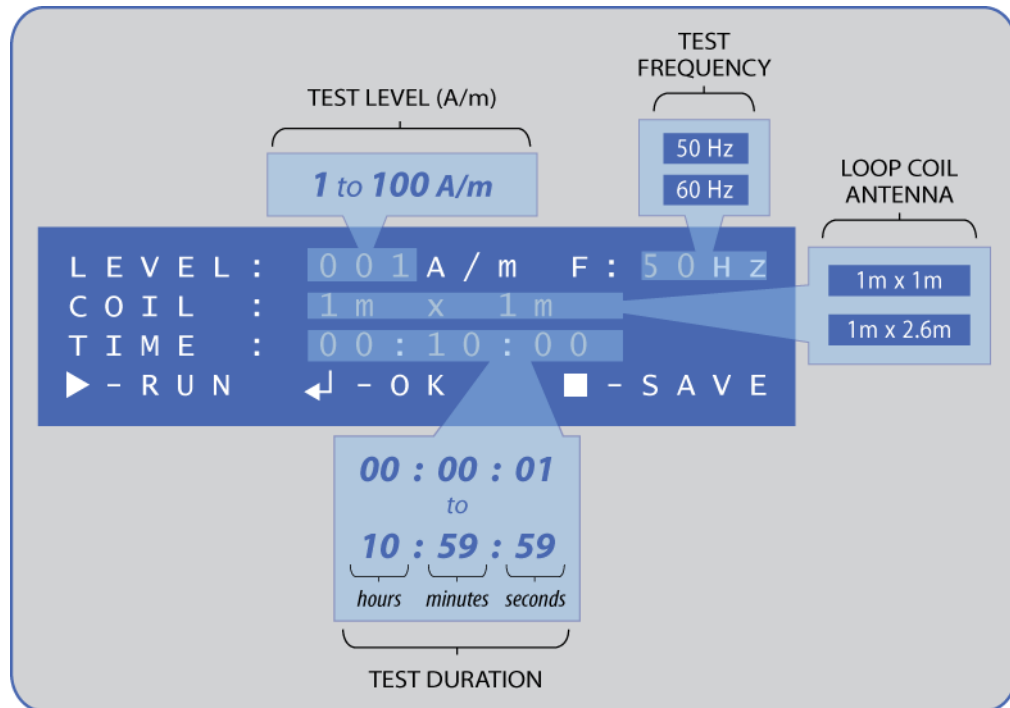

**Figure 13 - STANDARD Test Setup Menu Options**

**NOTE:** The generator output is limited to 120 amperes. The coil factor for the 1m x 2.6m loop coil is 0.68, which will limit the achievable test level with this antenna. If the entered test level (in A/m) divided by the coil factor exceeds 120 amperes, then the generator will display an error after the **▶** button is pressed to start the test. Refer to section 8 (Troubleshooting) for more details.

SECTION 6 - FRONT PANEL OPERATION



### 6.5 USER Test Setup Menu Screen

From this menu, the user is able to:

- select the desired **TEST LEVEL**;
- select the desired **TEST FREQUENCY**;
- enter the **COIL FACTOR (C.F.)** for the coil to be used;
- enter the **TIME**, or duration of the test;
- RUN** the test using the defined test parameters; and,
- SAVE** the test setup, so that it can be accessed later from the Quick Access Menu (see section 6.3).

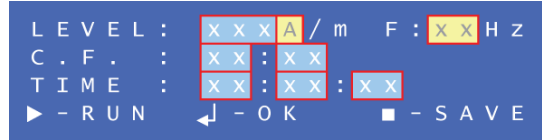

Shown in Figure 14 are the available menu options and/or allowed numeric ranges for the test parameters on the USER Test Setup Menu screen.

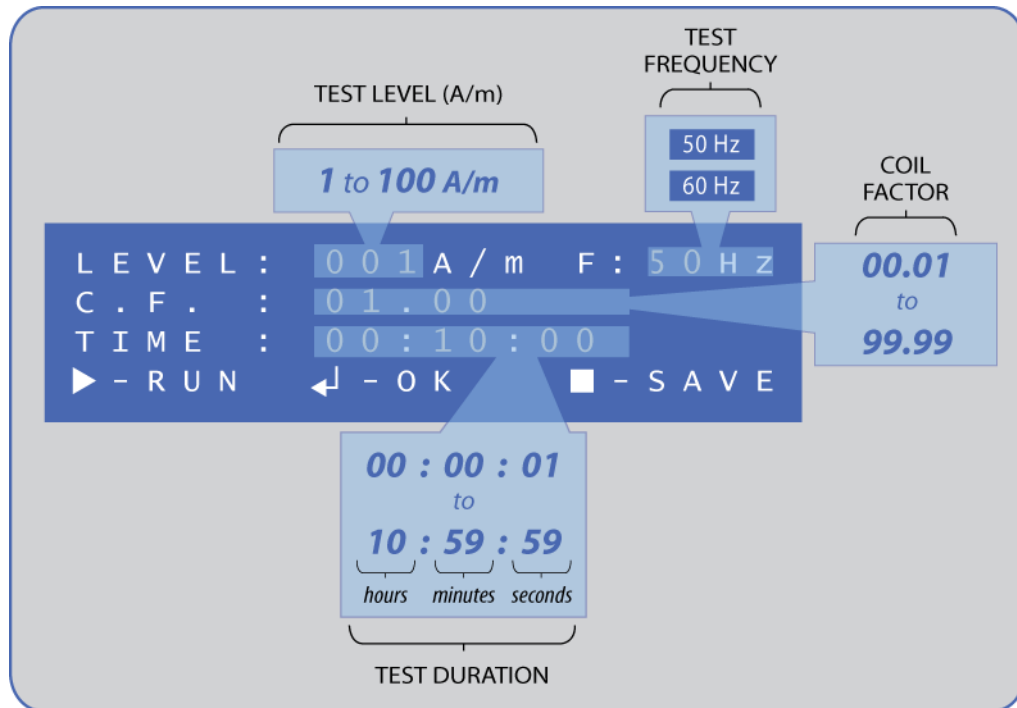

**Figure 14 - USER Test Setup Menu Options**

**NOTE:** The generator output is limited to 120 amperes. If the entered test level (in A/m) divided by the coil factor exceeds 120 amperes, then the generator will display an error after the  button is pressed to start the test. Refer to section 8 (Troubleshooting) for more details.

## 6.6 Test Setup Menus Navigation/Operation

In either the STANDARD or USER test setup menu screens, the user has the ability to change any of the test parameter fields which are highlighted/highlighted in Figure 15 using the blue control panel arrow/function buttons located on the front panel, to the right of the display, and also shown in Figure 15.

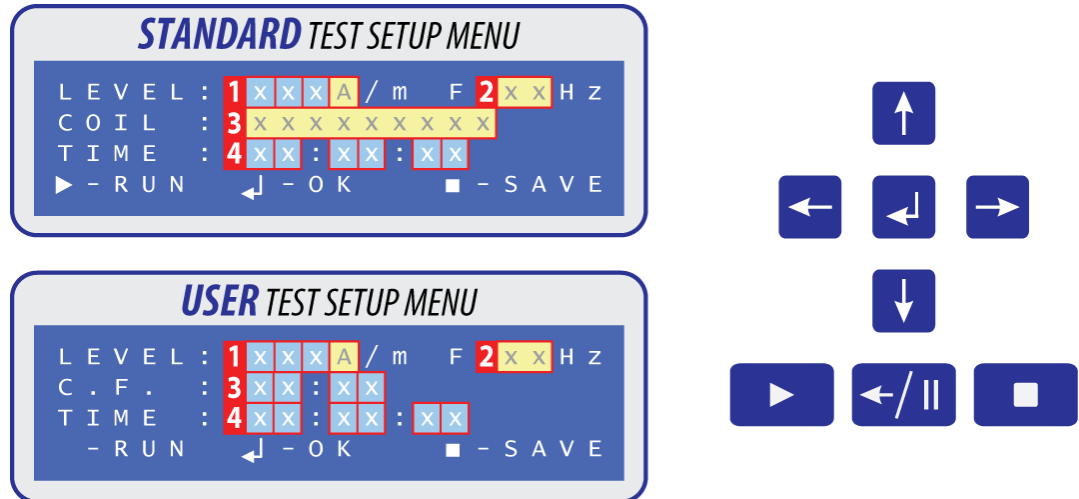

Figure 15 - User-Changeable Test Parameters

### 6.6.1 Menu Navigation

By default, the LEVEL field is selected on this menu. On the above diagram, the fields are numbered (#) in the order of selection. Whenever the button is pressed, the next field is selected. When the is pressed, the previous field is selected; or, if the first menu field was selected when pressed, the previous page is displayed.

### 6.6.2 Modifying Non-Numeric Surge Parameter Fields

When any highlighted (non-numeric) field is selected, the user can scroll through the available options for that field using the and buttons. Press the button once the desired option is selected. This will program your selection, and the next field on the menu will now be selected. The options available for each field are listed in Figure 13 and Figure 14 for the STANDARD and USER test setup menus, respectively.

### 6.6.3 Modifying Numeric Surge Parameter Fields

When any **highlighted** (numeric) field is selected, the user can modify the numeric value as shown below:

The values are set by modifying one digit at a time. Use the **↑ ↓** keys to increment/decrement the value of the selected digit. The allowed numeric ranges for each digit in each field are shown in Figure 16.

Use the **← →** keys to switch between selected digits as illustrated below.

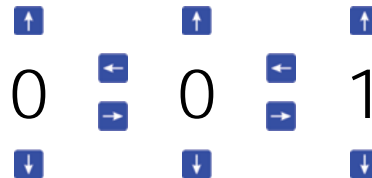

Press the **↵** button once the desired value is entered. This will program your selection, and the next field on the menu will be selected.

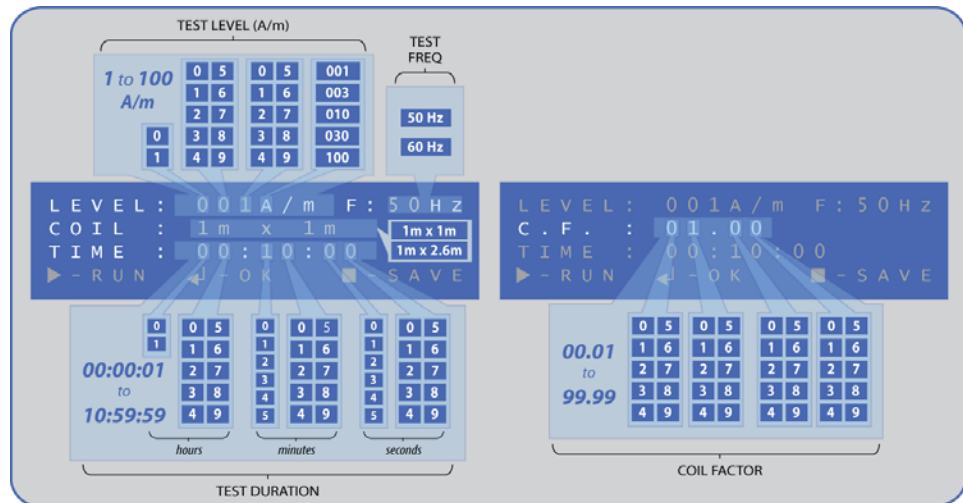

**Figure 16 - Test Setup Menu Options with Allowed Digit Ranges**

## 6.7 Run Test

Pressing  at any time on either test setup menu will run the test with the presently defined parameters.

After pressing , the bottom row becomes the STATUS line. The STATUS line indicates the present status of the generator.

```
LEVEL : 010 A / m   F : 50 Hz
C.F.   : 01.00
TIME   : 00:10:00
STATUS : SETTING LEVEL
```

First, the STATUS will show 'SETTING LEVEL', which indicates that the generator is adjusting the output frequency to the selected value, and incrementally adjusting the output current to the appropriate value based on the measured loop current and coil factor.

The level setting process normally takes less than one minute to complete, but under some circumstances, may take up to three (3) minutes. If an error occurs during the level setting process, refer to Section 8 (Troubleshooting).

Once the level setting process has completed, the test will commence automatically.

When the test starts, the STATUS line will be replaced by two real-time measurements:

```
LEVEL : 010 A / m
C.F.   : 01.00
TIME   : 00:04:15
Fo : 50 Hz   Io : 10.7 A
```

**Fo = Output Frequency**

**Io = Output Current**

During the test, it is normal for the output current value to vary slightly (5-10%). The output frequency should remain stable.

In addition, the TIME will now count down in real time from the set value to zero. When the TIME reaches zero, the STATUS line will reappear and show 'COMPLETED'.

```
LEVEL : 010 A / m   F : 50 Hz
C.F.   : 01.00
TIME   : 00:10:00
STATUS : COMPLETED
```

After completion of the test, press the  button to return to the TEST SETUP MENU screen.

If an error occurs during the test, refer to Section 8 (Troubleshooting).

### 6.7.1 Pausing the Test

At any point during the test, pressing the  key will immediately pause the test and "PAUSED" will be displayed as the generator status.

```
LEVEL : 010 A / m F : 50 Hz  
C.F. : 01.00  
TIME : 00:10:00  
STATUS : PAUSED
```

The test will remain paused until the test is resumed by pressing the  key.

### 6.7.2 Aborting the Test

At any point during the test, pressing the  key will immediately abort the test process and "ABORTED" will be displayed as the generator status.

```
LEVEL : 010 A / m F : 50 Hz  
C.F. : 01.00  
TIME : 00:04:11  
STATUS : ABORTED
```

After aborting the test, press the  key to return to the TEST SETUP MENU screen.

## 6.8 Save Test

Pressing **■** at any time on either test setup menu screen will save the current test setup parameters into one of the ten available non-volatile memory locations.

```
LEVEL : 001A / m F : 50 Hz
COIL  : 1m x 1m
TIME  : 00 : 10 : 00
▶ - RUN ◀ - OK ■ - SAVE
```

```
SAVED SUCCESSFULLY
AT MEMORY SLOT X
```

If there is at least one empty memory slot remaining, the screen to the left will be displayed, which will indicate the memory slot into which the test setup is saved.

If there are no memory slots available, the screen to the right will be displayed.

```
MEMORY FULL
DO YOU WANT TO
REPLACE OLD ENTRY ?
YES NO
```

Use the **◀ ▶** buttons to select YES or NO, and then press the **⏏** button. The NO option will return you to the setup screen without saving. Selecting the YES option will allow you to select which saved task will be replaced.

```
1) TASK 1
2) TASK 2
3) TASK 3
■ - CANCEL ◀ - REPLACE
```

Use the **↑ ↓** buttons to navigate through the list of previously saved tasks until the task you want to overwrite is selected. Then, press the

**⏏** button to overwrite the selected task with the present test setup.

Press the **■** button to cancel this operation if you decide not to overwrite any of the previously saved tasks.

To DELETE ALL saved tasks from the QUICK MENU, hold down the **■** button for three seconds; the screen to the right will appear.

```
DO YOU WANT TO
DELETE ALL SAVED
TASKS ?
YES NO
```

The default selection for this screen is NO. Pressing **⏏** without changing the selection will return you to the QUICK MENU. To select YES, press the **◀** button to move the cursor and then press the **⏏** button.

## 7.0 Performance of Tests

Tests are performed according to the procedures described in the IEC 61000-4-8 standard.

For tests performed using the 1m x 1m or 1m x 2.6m inductive standard coil, refer to section 7.1.

For test performed using any other (non-standard) inductive coil, refer to section 7.2.

If the EUT does not fit entirely within the 3 dB test volume of the inductive coil, then the test shall be repeated by moving and shifting the inductive coils, in order to test the whole volume of the EUT for each orthogonal direction. The moving of the inductive coil in steps corresponding to 50% of the shortest side of the coil gives overlapping test fields.

The following sections provide more detail relating to the 3 dB test volume of inductive coils.

Illustrated in Figure 17 are the EUT/coil arrangements for testing a table-top EUT in three axis.

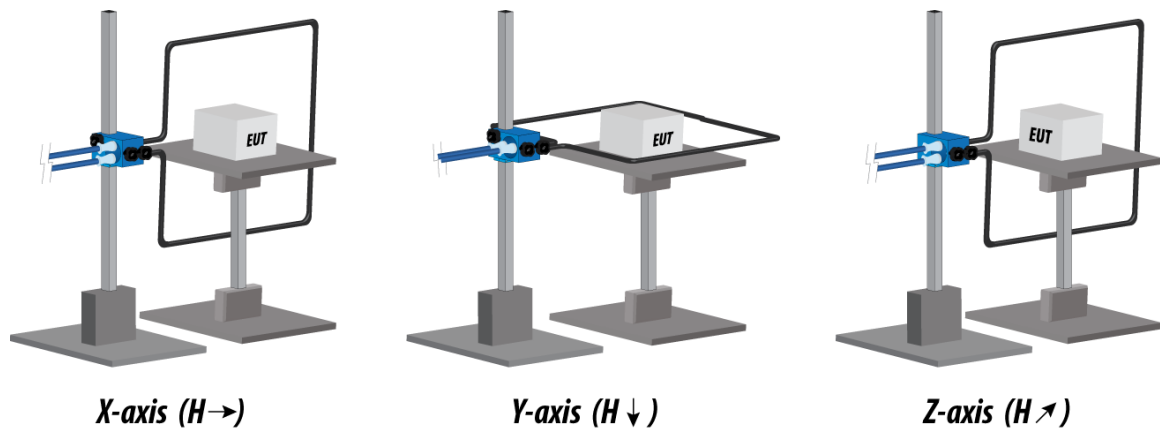

**Figure 17 - Basic Test Setup for Table Top EUT (3-axis)**

Refer to the IEC 61000-4-8 document for further details.

## 7.1 Performing Tests with Inductive Standard Coils

When an inductive standard coil is used, such as the 1m x 1m and 1m x 2.6m single-turn coils, no field verification or field calibration is necessary, as the coil factor and test volume are known quantities.

The coil factor for either antenna is applied automatically when the antenna is selected. The test volume for the 1m x 1m inductive standard coil is 0.6m x 0.6m x 0.5m (height). The test volume for the 1m x 2.6m inductive standard coil is 0.6m x 2m (height) x 0.6m.

Use the STANDARD test setup menu to configure the four variable test parameters as per your testing requirements:

- TEST LEVEL: **1 to 100 A/m**
- TEST FREQ.: **50 Hz or 60 Hz**
- COIL: **1m x 1m or 1m x 2.6m**
- TIME: **00:00:01 to 10:59:59**

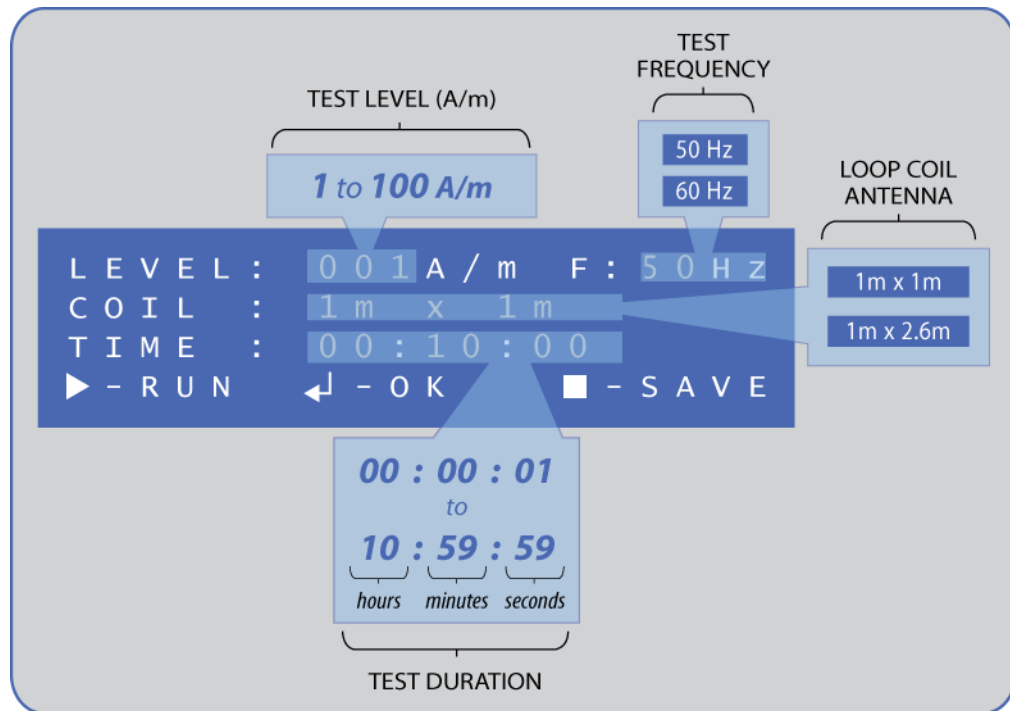

**Figure 18 - STANDARD Test Setup Menu Options**

**NOTE:** The generator output is limited to 120 amperes. The coil factor for the 1m x 2.6m loop coil is 0.68, which will limit the achievable test level with this antenna. If the entered test level (in A/m) divided by the coil factor exceeds 120 amperes, then the generator will display an error after the ▶ button is pressed to start the test. Refer to section 8 (Troubleshooting) for more details.

### SECTION 7 - PERFORMANCE OF TESTS



## 7.2 Preparation for Tests to be Performed with Inductive Non-Standard Coils

When any coil other than the two standard 1m x 1m and 1m x 2.6m single-turn coils is used, and the **coil factor** and/or **test volume** are not known, they must be determined by performing magnetic field measurements without the EUT present.

### 7.2.1 Determination of Coil Factor

The coil factor is the ratio between the magnetic field generated by an inductive coil and the corresponding current value.

In order to determine the coil factor for any antenna, the magnitude of the field at the center of the coil must be measured using a suitable magnetic field meter while monitoring the current through the coil. The measured field (in A/m) divided by the coil current (in amperes) is the coil factor.

The APF-5060 Magnetic Field Generator, along with a suitable magnetic field meter are used to determine the coil factor according to the following procedure:

#### Step #1

Using the USER Test Setup Menu, set the four variable test parameters to the values shown below:

TEST LEVEL: **30 A/m**

TEST FREQ.: **50 Hz**

COIL FACTOR: **01.00**

TIME: **00:10:00**

```

LEVEL : 030 A / m   F : 50 Hz
C . F . : 01 . 00
T I M E : 00 : 10 : 00
▶ - R U N   ◀ - O K   ■ - S A V E
    
```

#### Step #2

Place the magnetic field meter with its antenna/sensor at the center of the coil as shown in Figure 19.

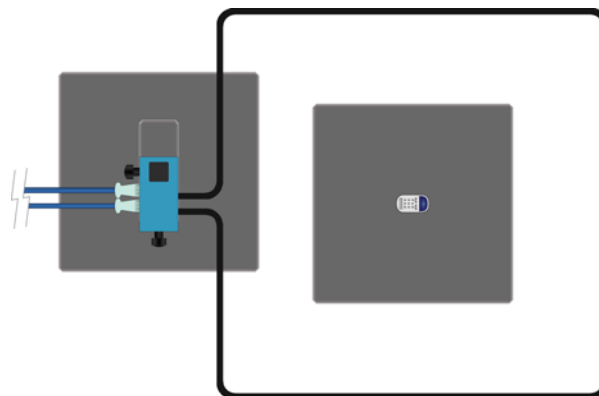

**Figure 19 - Setup for Magnetic Field Measurement for Coil Factor Determination**

**Step #3** Press the  button on the generator to start the test. Once the level has been set and the test starts (*the time displayed on the generator is counting down*), proceed to the next step.

**Step #4** Find the maximum reading by adjusting the position, angle and orientation of the magnetic field meter's antenna/sensor, while maintaining its location in the center of the coil.

**Step #5** Measure and record the maximum magnitude of the field measured with the magnetic field meter.

NOTE: *Most conventional meters display the field magnitude in Gauss and/or Tesla units. The measured value(s) must be converted to Amps per meter (A/m) units. Given in Equation 1 are the relevant conversion formulae.*

**Equation 1 - Conversion from Gauss & Tesla to A/m**

$$\frac{\text{Tesla (T)} \times 10^7}{4\pi} = \frac{\text{Gauss (G)} \times 10^3}{4\pi} = \text{Amps per meter (A/m)}$$

$$\frac{\text{microtesla } (\mu\text{T})}{1.257} = \text{Amps per meter (A/m)}$$

$$\frac{\text{milligauss (mG)}}{12.57} = \text{Amps per meter (A/m)}$$

**Step #6** Observe and record the ***I<sub>o</sub>*** value (in Amperes) which is displayed on the bottom right corner of the front panel display on the generator.

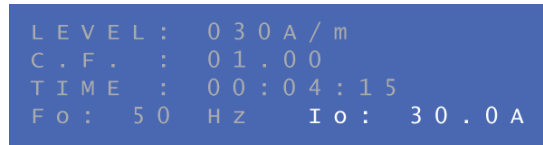

```

LEVEL : 030 A / m
C.F. : 01.00
TIME : 00:04:15
Fo : 50 Hz   Io : 30.0 A
    
```

**Step #7**

Using Equation 2, calculate the coil factor by dividing the magnetic field strength measured during Step #3 by the current measured during Step #4.

**Equation 2 - Calculation of Coil Factor (C.F.)**

$$\text{Coil Factor (C.F.)} = \frac{\text{Measured Field in Amps per meter (A/m)}}{\text{Measured Current through Loop Coil in Amps (A)}}$$

**EXAMPLE:** For a measured field strength of **25.5 A/m** and measured coil current of **30A**, the coil factor is:

$$\frac{25.5 \text{ Amps per meter}}{30 \text{ Amperes}} = 0.85 \text{ (Coil Factor)}$$

When testing is performed, the coil factor is entered into the APF-5060 USER test setup menu. The generator uses the entered coil factor to determine the required output current to generate a given field strength as shown in Equation 3.

**Equation 3 - Calculation of Generator Output/Coil Current**

$$\text{Generator Output/Coil Current (in Amperes)} = \frac{\text{Magnetic Field Strength in Amps per meter (A/m)}}{\text{Coil Factor (C.F.)}}$$

**EXAMPLE:** To generate a **100 A/m** magnetic field using a loop with a **0.85 coil factor**, the required generator output current, or loop coil current is calculated as follows:

```

LEVEL : 100 A / m   F : 50 HZ
C.F.   : 00.85
TIME   : 00:10:00
- RUN   - OK       - SAVE
    
```

$$\frac{100 \text{ A/m}}{0.85 \text{ (Coil Factor)}} = 117.6 \text{ Amperes (Generator Output/Coil Current)}$$

**7.2.2 Determination of Test Volume**

The test volume of a coil is a three-dimensional area centered within the coil periphery and extending outwards in all directions, where the field varies by no more than  $\pm 3$  dB. The test volume area should fully encompass the EUT during testing. Illustrated in Figure 20, as an example, is the test volume for a 1m x 1m inductive standard coil.

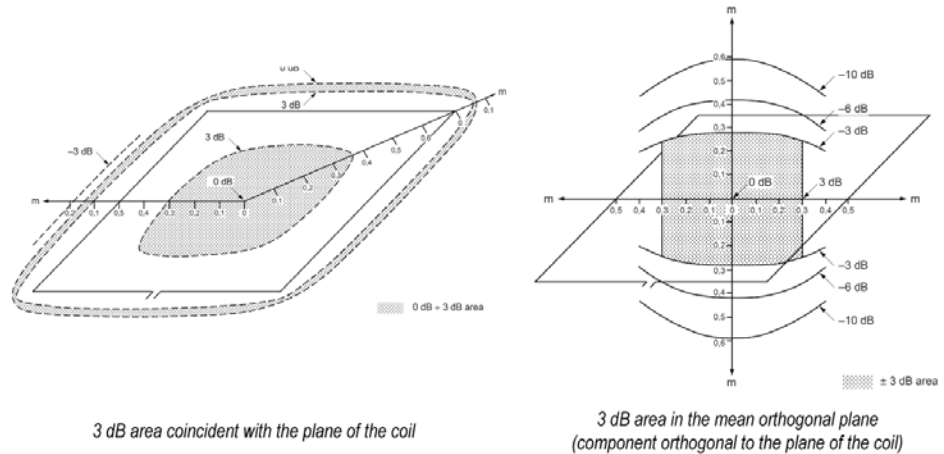

**Figure 20 - Test Volume for a 1m x 1m Inductive Standard Coil**

The test volume is determined by establishing a fixed magnetic field with the coil in question, with no EUT present. Magnetic field measurements are then performed successively, while systematically and incrementally adjusting the position of the field probe within the field between measurements. Refer to the IEC 61000-4-8 standard for more information.

### 7.3 Performing Tests with Inductive Non-Standard Coils

Once the coil factor and test volume for the coil to be used are known, use the USER test setup menu to configure the four variable test parameters as per your testing requirements:

**TEST LEVEL:** 1 to 100 A/m

**TEST FREQ.:** 50 Hz or 60 Hz

**COIL FACTOR:** 00.01 to 99.99

**TIME:** 00:00:01 to 10:59:59

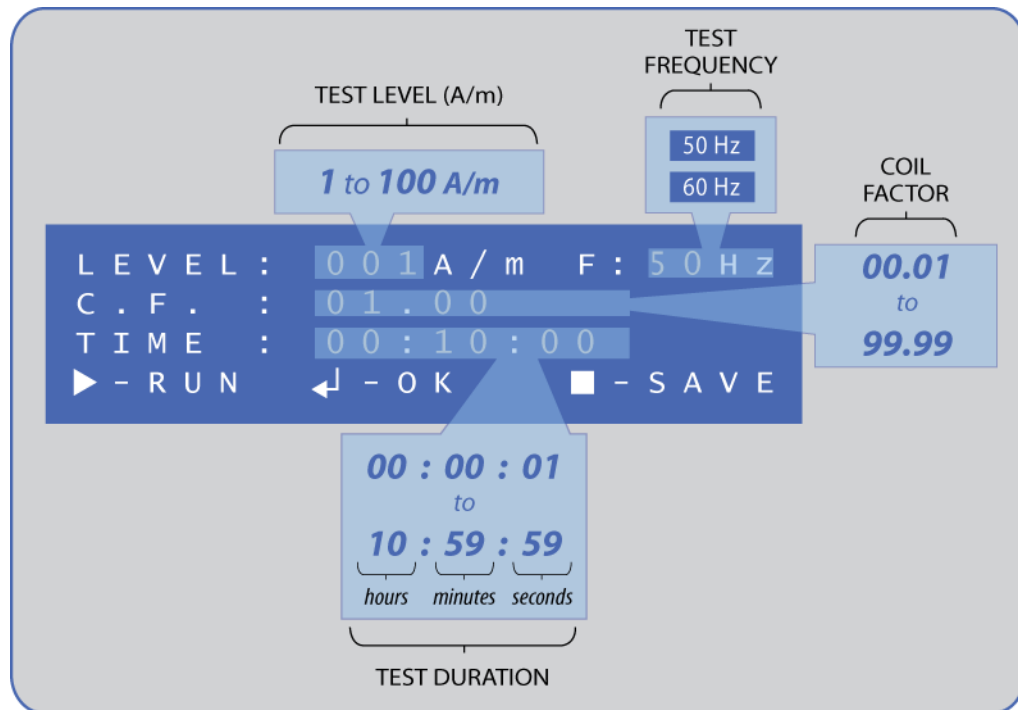

**Figure 21 - USER Test Setup Menu Options**

The generator output is limited to 120 amperes. If the entered test level (in A/m) divided by the coil factor exceeds 120 amperes, then the generator will display an error after the  button is pressed to start the test. Refer to section 8 (Troubleshooting) for more details.

## 8.0 Troubleshooting

The following sections contain possible causes for error messages displayed by the generator.

### 8.1 **ERROR MESSAGE – Current Required to Set the Field Exceeds 120 Amps**

The generator will display this error when the required current exceeds its 120 ampere limit.

```
CURRENT REQUIRED  
TO SET THE FIELD  
EXCEEDS 120 AMPS  
CHECK SETTINGS
```

The required current is determined using Equation 3; by dividing the Magnetic Field Strength (in A/m) by the coil factor. If this value exceeds 120 amperes, the generator will display this error as soon as the  button is pressed to start the test.

### 8.2 **ERROR MESSAGE – Unexpected Change in Output Current**

The generator will display this error whenever there is a sudden change in the output current while a test is being performed.

```
UNEXPECTED CHANGE IN  
OUTPUT CURRENT  
CHECK CONNECTIONS  
STATUS: ABORTED
```

Possible causes include:

- Disconnected generator output cable.
- Disconnected antenna.
- Faulty cable/antenna connection.
- Generator failure

### 8.3 **ERROR MESSAGE – Unable to Set Level**

The generator will display this error when the level setting process is unable to be completed.

```
UNABLE TO SET LEVEL  
CHECK SETTINGS AND  
ANTENNA CONNECTIONS  
STATUS: ABORTED
```

Possible causes include:

- Disconnected generator output cable.
- Disconnected antenna.
- Faulty cable/antenna connection.
- The output current level, based on the test level divided by the coil factor, is too low (less than 1 ampere).
- Generator failure.

## SECTION 8 - TROUBLESHOOTING

## 9.0 Warranty

Com-Power warrants to its Customers that the products it manufactures will be free from defects in materials and workmanship for a period of three (3) years. This warranty shall not apply to:

- Transport damages during shipment from your plant.
- Damages due to poor packaging.
- Products operated outside their specifications.
- Products Improperly maintained or modified.
- Consumable items such as fuses, power cords, cables, etc.
- Normal wear
- Calibration
- Products shipped outside the United States without the prior knowledge of Com-Power.

In addition, Com-Power shall not be obliged to provide service under this warranty to repair damage resulting from attempts to install, repair, service or modify the instrument by personnel other than Com-Power service representatives.

Under no circumstances does Com-Power recognize or assume liability for any loss, damage or expense arising, either directly or indirectly, from the use or handling of this product, or any inability to use this product separately or in combination with any other equipment.

When requesting warranty services, it is recommended that the original packaging material be used for shipping. Damage due to improper packaging will void warranty.

In the case of repair or complaint, Please visit our website [www.com-power.com](http://www.com-power.com) and fill out the service request form (<http://com-power.com/repairservicereq.asp>). Our technical assistance personnel will contact you with an RMA number. The RMA number should be displayed in a prominent location on the packaging and on the product, along with a description of the problem, and your contact information.

## **9.0 Maintenance**

This product contains no user serviceable parts. If the unit does not operate or needs calibration, please contact Com-Power Corporation. Any modifications or repairs performed on the unit by someone other than an authorized factory trained technician will void warranty.

The exterior surface may be cleaned with mild detergent and then be wiped with a dry, clean, lint-free cloth. Use care to avoid liquids or other foreign objects entering the chassis.